

# MIDGET

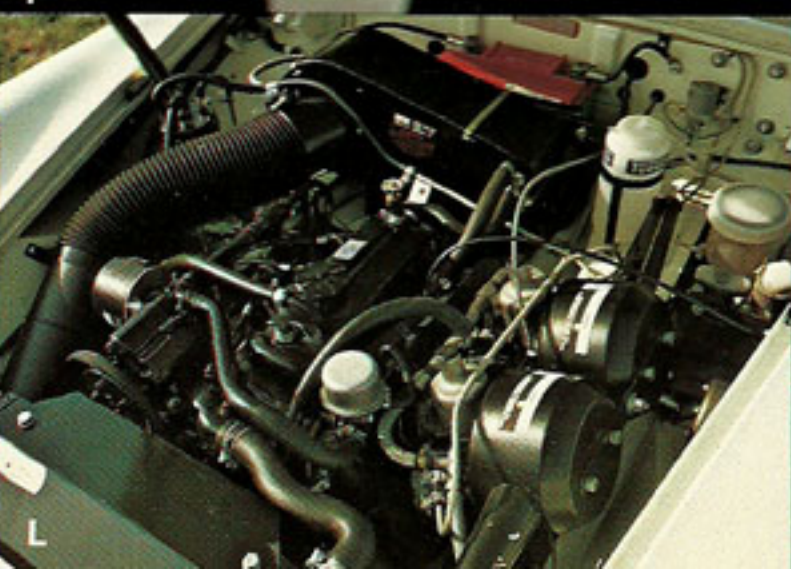

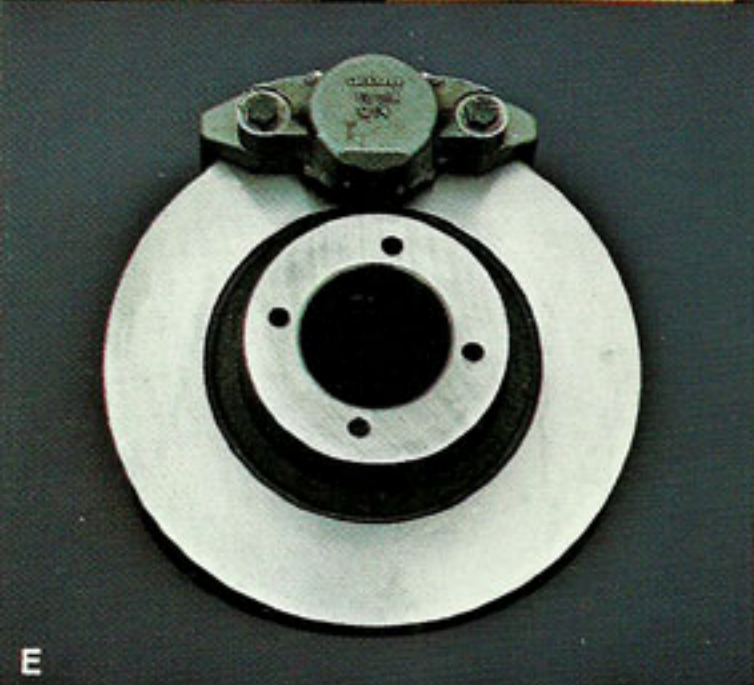

Above: Settle in. There's plenty of room for you and a friend in the 1973 Midget, the traditional sports car that is as contemporary as today. (A) & (B) Up close, the Midget shows the kind of detailing and careful fitting that's MG tradition. (C) A close-ratio 4 that's smooth and sure. (D) The new alloy spoke steering wheel links up to precise rack and pinion steering. (E) The Midget has a dual hydraulic braking system with 8 1/4 inch disc brakes up front. (F) It's rock, pop, jazz or long-hair with the optional AM solid-state radio. (G) There's a lot in a Midget package including all-steel monocoque construction. (H) Mag-style wheels and radial ply tires are standard, the brushed aluminum trim rims optional. (I) Full instrumentation including tachometer, speedometer, fuel, oil pressure and water temperature gauges. (J) Bucket seats have adjustable head restraints. Navy interior is standard with Damask Red, Blaze, Harvest Gold, Limeflower, Glacier White and Bronze Yellow; Ochre, a bright yellow, is standard with Black Tulip, Teal Blue and Green Mallard. (K) Room enough for a week-end of gear in the lockable trunk. (L) A proven champion, the Midget 1275 c.c. twin-carb engine. (M) Keeping the cheer in and the chill out is as easy as putting up the durable vinyl top.

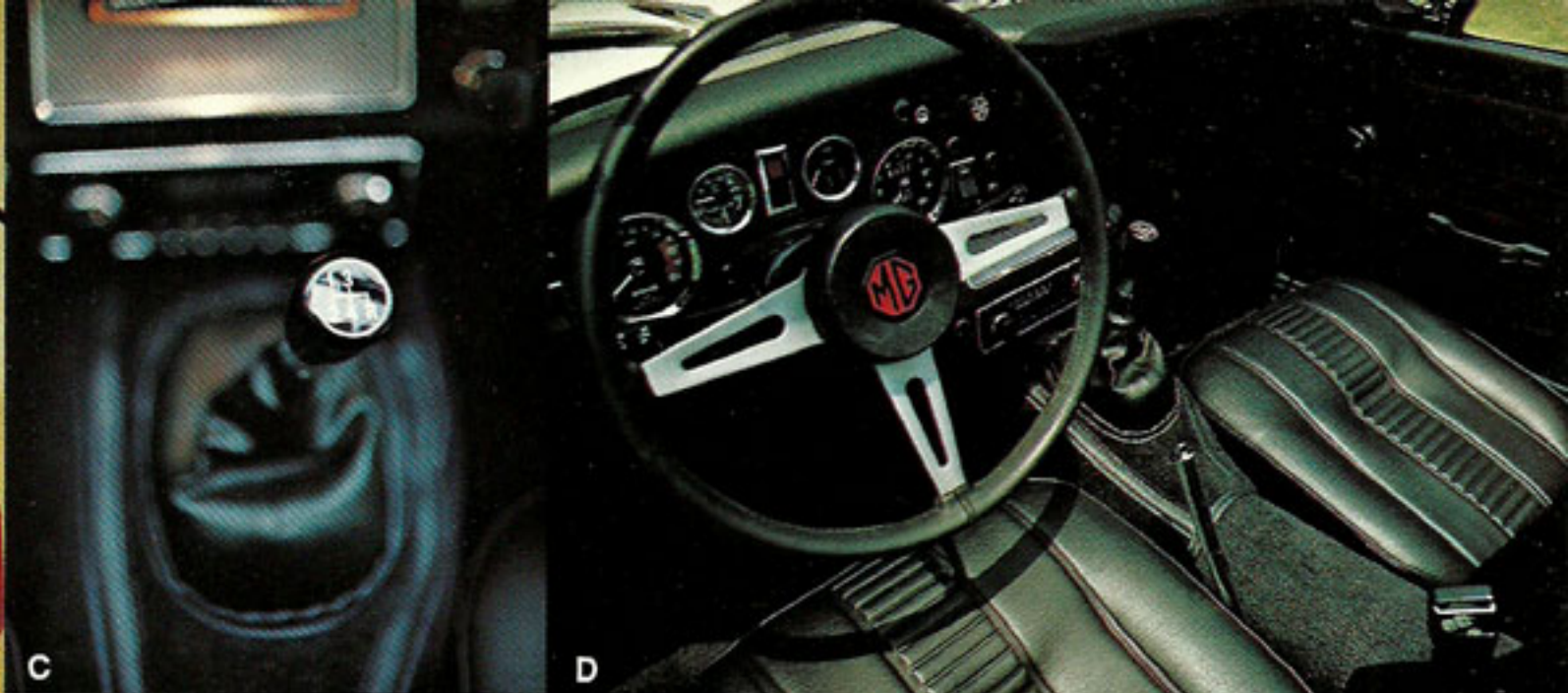
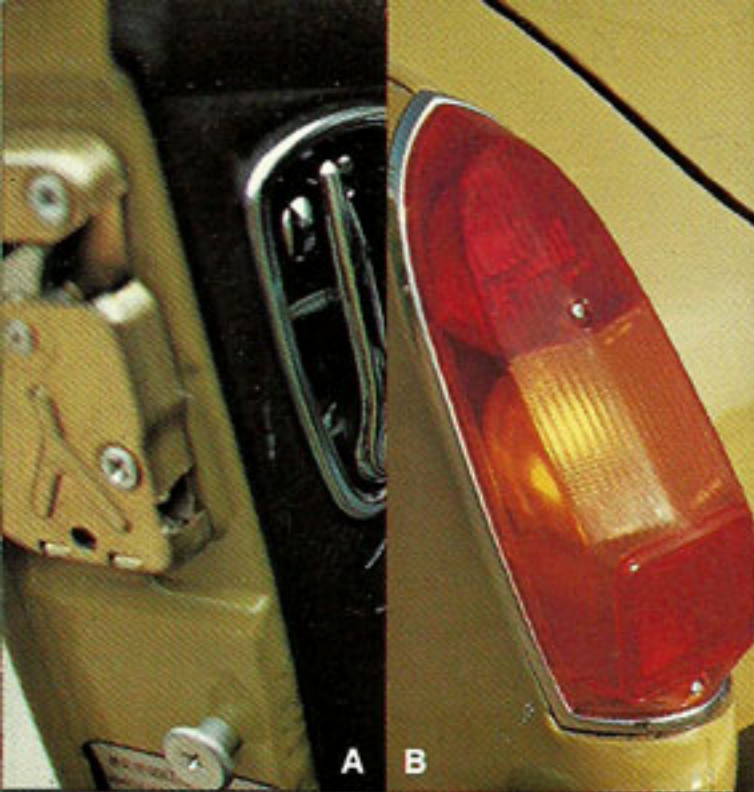

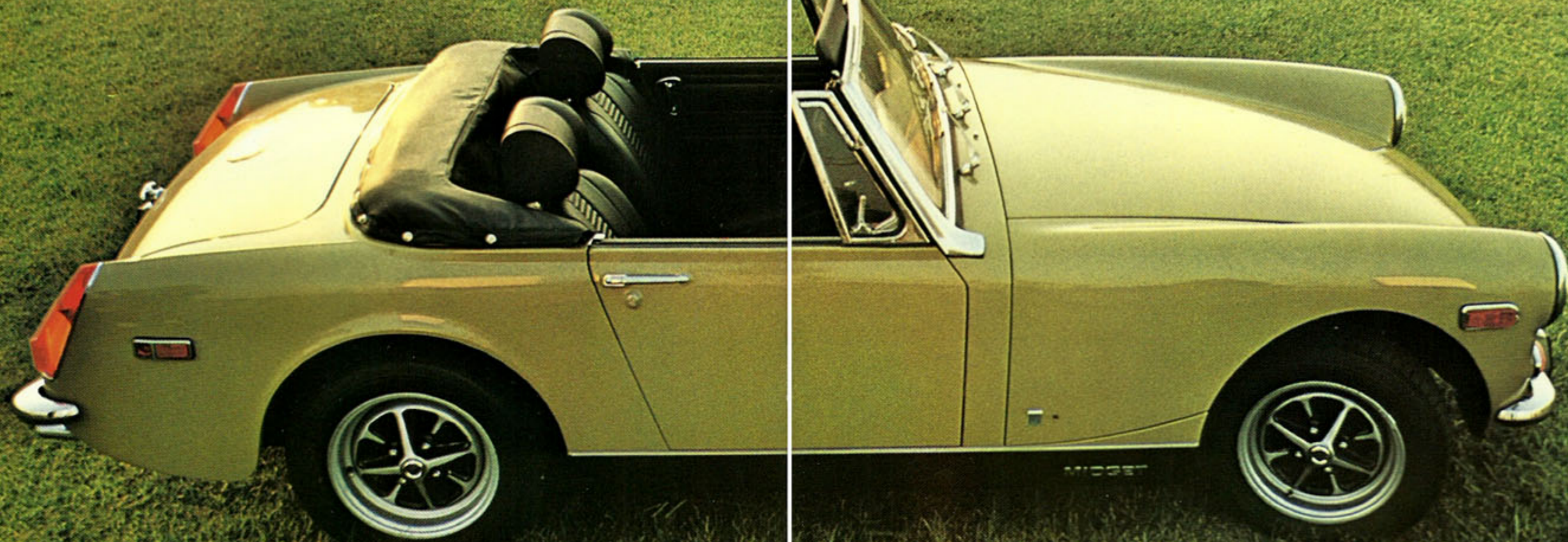
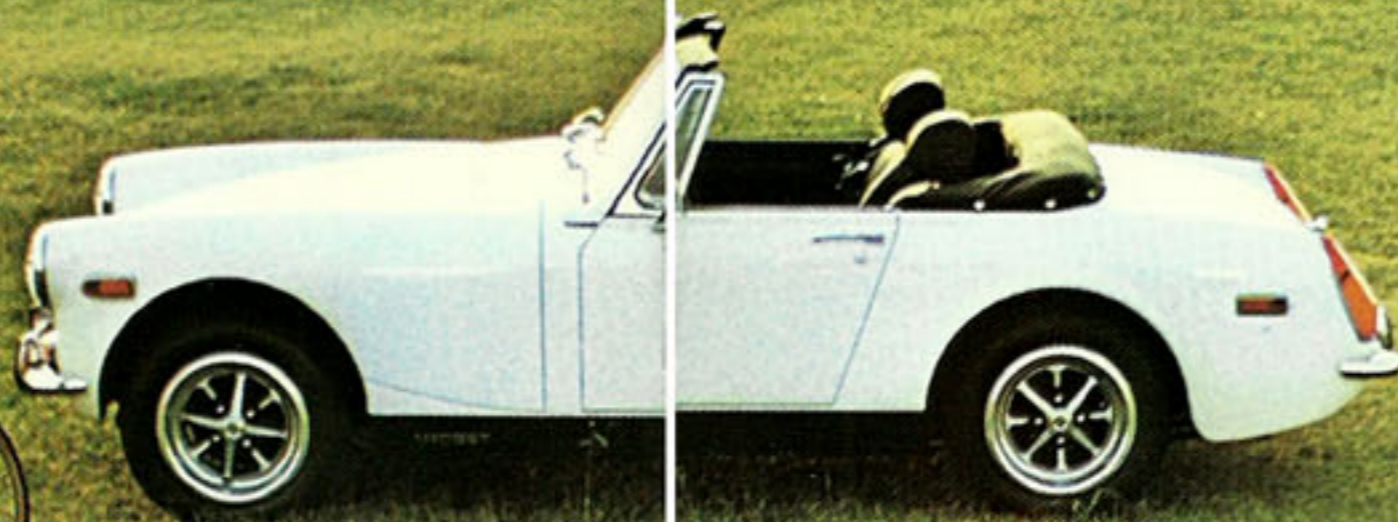

The MG Midget is one sports car that's 'priced to go'. Its performance profile harks back to the classic TC's that brought sports car motoring to America. Yet of all the proven winners now in national SCCA racing, the Midget is the one with the lowest price tag. That's a price and performance combination no other sports car can beat. So take advantage of the Midget's special brand of excitement. Its favorite paths are winding country roads and twisting mountain pikes, but it also has the stamina to keep you out front on the busiest stretch of expressway. Go with Midget and you'll be going with the best.

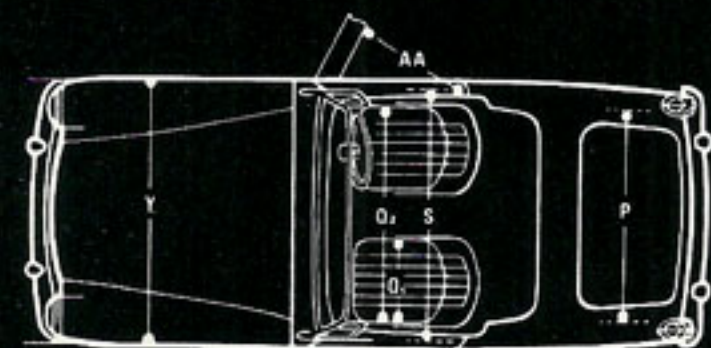
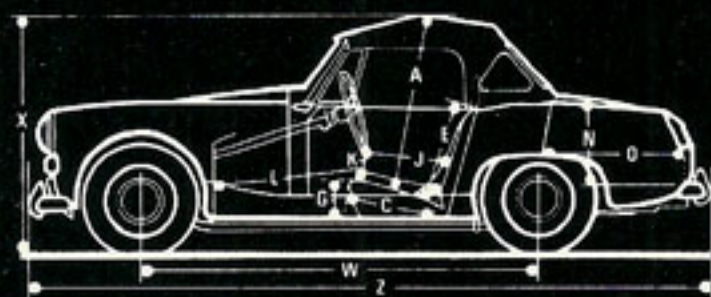

Front seat head room	A	35½ in.
Front seat cushion depth	C	19 in.
Front seat squab height above cushion	E	19 in.
Front seat cushion height above floor	G	8½ in.
Steering-wheel to squab—max.	J	17¼ in.
Steering-wheel to squab—min.	J	13¾ in.
Steering-wheel to cushion	K	5 in.
Front seat leg reach—max.	L	44¼ in.
Front seat leg reach—min.	L	41 in.
Luggage trunk height	N	15½ in.
Luggage trunk depth	O	27½ in.
Luggage trunk width	P	42 in.
Front seat cushion width—individual	Q1	17 in.
Front seat cushion—overall width	Q2	44¼ in.
Width between front doors—max.	S	48½ in.
Wheelbase	W	80 in.
Overall height (top up)	X	48¾ in.
Overall width	Y	54¾ in.
Overall length with over-riders	Z	137¾ in.
Front door entry width	AA	26 in.
Ground clearance	—	5 in.
Approx. weight	—	1,512 lb.

**BODY COLORS**

	DAMASK RED	GLACIER WHITE	BLAZE
SIX BODY COLORS COME WITH NAVY INTERIOR.			
	BRONZE YELLOW	HARVEST GOLD	LIMEFLOWER
THREE BODY COLORS COME WITH OCHRE INTERIOR.	BLACK TULIP	TEAL BLUE	GREEN MALLARD

## SPECIFICATIONS

### ENGINE:

4-cylinder, in-line, overhead valve.  
3-bearing counter-balanced crankshaft.  
Exhaust and evaporative emission-control.  
Compression ratio: 8.0:1  
Bore: 2.78 in.  
Stroke: 3.2 in.  
Displacement: 1275 c.c. (77.9 cu. in.)  
Horsepower (SAE): 54.5 b.h.p. @ 5,500 r.p.m.  
Torque (SAE): 67 lb./ft. @ 3,250 r.p.m.  
Carburetion: Twin 1.25 in. S.U. semi-down-draught.  
Fuel Pump: High-pressure S.U. electric.  
Fuel Tank Capacity: 7.5 gallons.

### TRANSMISSION:

Close-ratio, four-speed with synchromesh on second, third, and fourth gears.  
Clutch: Diaphragm type, 6.5 in. diameter, hydraulically operated.

Rear Axle: Three-quarter floating, hypoid final reduction gears.  
Ratio: 3.9:1

### Overall gear ratios:

Reverse	16.1:1
First	12.5:1
Second	7.5:1
Third	5.3:1
Fourth	3.9:1

### STEERING:

Direct rack and pinion.  
Steering Wheel: 15.5 in. diameter alloy spoke, bound rim.  
Turns—lock to lock: 2.25  
Energy-absorbing steering column.

### SUSPENSION:

Front: Independent, coil springs and lever-type shock absorbers.

Rear: Semi-elliptic springs with double acting lever-type shock absorbers.

### BRAKES:

Dual hydraulic braking systems.  
Front: 8.25 in. diameter disc brakes.  
Rear: 7 in. diameter drum brakes.

### ROAD WHEELS:

Rostyle wheels, 13 in. diameter, fitted with 145 x 13 radial-ply tires.

### PERFORMANCE DATA:

Maximum Speed: 90 m.p.h.  
Acceleration: 0-60 m.p.h.—16.5 sec.  
Standing quarter mile: 20.3 sec.  
Road Speed at 1,000 r.p.m. in top gear: 16.7 m.p.h.

### ELECTRICAL:

Negative ground, 12-volt system.  
Battery: 40 amp./hr.  
Alternator with solid-state regulator.  
Electric 3-blade windshield wiper system, 2-speed.  
Electric windshield washers.  
Twin backup lights.  
Twin windtone horns controlled in center steering wheel.  
Emergency flashing warning lights.  
Heater/defroster with high-speed blower\*, and fresh-air ventilation.  
\*Except Hawaii and Puerto Rico.

### INSTRUMENTS:

Speedometer with trip odometer.  
Electric tachometer.  
Oil pressure, water temperature, and fuel gauges.  
Ignition, brake pressure, and high beam warning lights.  
Manual choke.  
All instruments and switches set in no-glare, padded dash.  
Door-operated courtesy light.

### BODY:

Steel mono-construction.  
Interior hood release and automatic hood support.  
Locking trunk with automatic lid support.  
Automatic trunk light.  
Curved laminated windshield.  
Full positive anti-burst door latches.

Roll-up windows and hinged front vents.  
Waterproof folding top.  
Mirrors: exterior adjustable; interior adjustable day-night type.  
Lighted side markers front and rear.  
Rubber insert bumper overriders front and rear.

### INTERIOR:

Padded sunvisors.  
Reclining washable ambla bucket seats with adjustable head restraints.  
Safety 3-point seat belts.  
Cigarette lighter and ash tray.  
Lockable glove box.  
Fitted carpeting with rubber floor mats.  
Gearshift gaiter.

### OPTIONAL EQUIPMENT AND ACCESSORIES:

Whitewall radial-ply tires.  
Dunlop 60-spoke center-lock wire wheels.  
Wheel trim rims.  
Removable hardtop.  
Tonneau cover.  
Anti-roll bar.  
Oil cooler.  
Solid-state AM radio.  
Center console.  
Electric clock.  
Luggage rack (ski adapters available).  
Grille guard and rear bumper guard.  
Wood gearshift knob, rubber floor mats, and a full range of other sports car accessories.  
Optional Racing Equipment: a full line of approved competition parts.

THE MG MIDGET CONFORMS TO U.S. FEDERAL MOTOR VEHICLE SAFETY AND AIR POLLUTION STANDARDS APPLICABLE AT ITS DATE OF MANUFACTURE.

SPECIFICATIONS AND COLORS SUBJECT TO CHANGE WITHOUT NOTICE.



The up-front view—clean and crisp.  
Like the first MG Midget in 1928,  
today's Midget is still the leader  
in sports car value.



BRITISH LEYLAND MOTORS INC., LEONIA, NEW JERSEY 07605



LITHO U.S.A. AMGM-500M 10/72